

ROTORCRAFT SERVICES GROUP

30-145-16-001 Rev. -

Air Medical Services Interior

For

AIRBUS H145 Series Helicopter

This document contains information confidential and proprietary to Rotorcraft Services Group, Inc. and to its subsidiaries. The document and information contained herein is intended strictly for the use of the Customer and shall not be duplicated, used, or disclosed, in whole or in part, for any purpose other than to evaluate this proposal.

TABLE OF CONTENTS

1. ROTORCRAFT SERVICES GROUP.....	3
2. OVERVIEW	4
2.1 Introduction	4
Technical Documentation	28
Program Management.....	28
Program Schedule	28
After Sales Engineering Support	28
Contract Configuration Control	29
Engineering Change Control.....	29
Identification and Markings	29
Location of Service Performance.....	29
New parts	29

1. **AMS HELI DESIGN and ROTORCRAFT SERVICES GROUP**

AMS HELI DESIGN is a helicopter interior manufacturer specialized into Emergency Medical Services interiors and parts. AMS's products include interiors for Leonardo and Airbus helicopters as well as Medical mounts, Neonatal transports decks, and other parts PMA parts. AMS engineers, certifies and manufactures under its own Part 21 PMA all the products.

Rotorcraft Services Group, Inc. (RSG) is an integrated helicopter services organization that provides heavy maintenance and modification services, engineering and product development and manufacturing services through its current subsidiaries, RSG Aviation, RSG AeroDesign and RSG Products. The company's highly skilled technicians, senior engineers and specialists, draw on extensive working experience with major commercial and military programs to develop and to certify expert solutions for the VIP, Law Enforcement and EMS markets.

AMS and RSG combines their unique experience and capabilities to offer integrated services thought to fulfill customer needs and offer key in hand product design, integration, support. Services offered:

- Major Repair and Overhaul (MRO) Services for Military and Civil Aircraft
- Nose to Tail Phase and Programmed Depot Maintenance (PDM) Services
- Modernization and Service Life Extension (SLEP)
- Aircraft Weapons Systems Integration and Qualification
- Avionics & Electrical Systems Upgrades and Repairs
- Airworthiness Engineering Services & Support
- Aircraft parts sales and obsolescence management
- Defense Contract Management Agency (DCMA) Approved
- ISO-9001:2008, AS9100C Approved Engineering and Manufacturing Organization
- FAA Part 145 Aircraft Modification and Repair Services (Certificate # RV1R466K)
- ANAC Part 145 Aircraft Modification and Repair Services (Certificate # 0712-01)
- Airbus Helicopters Approved Service Center
- Bell Helicopters Approved Service Center
- FAA Part 21 Parts Manufacturing Approval (PMA)
- Approved Supplier for Airbus Helicopters, Bell Helicopter, Changhe Aircraft Industries, Enstrom Helicopter, Fokker, Hafei Aviation Industry, Korean Aerospace Industry, Leonardo S.p.A., PT Dirgantara Indonesia, SAFRAN USA, Sikorsky Aircraft.

2. OVERVIEW

2.1 Introduction

The Airbus H145 multirole helicopter offers outstanding performance with large unobstructed rear cabin space and high visibility throughout. These features make the aircraft an ideal air medical platform that is well suited for urgent care delivery, loading/unloading, and for crew comfort and safety. Up to three medical attendants have full access to patient and can perform lifesaving procedures while remaining belted. Other features include:

- Rear and side patient loading options
- Full body access
- Two patient capabilities
- Large cabin windows for excellent visibility and natural lighting
- Two pilot capability regardless of number of patients
- Unobstructed emergency egress

RSG's advanced medical interior design for the H145 helicopter offers flexible lightweight solutions for trauma, cardiac and neonatal transport. The new Emergency Patient In-flight Care (EPIC) modules provide patient focused intensive care delivery system that can be quickly tailored to the specific medical program needs.



2.2 Primary Patient Loading System (PLS)

The wheeled patient loading system is designed to meet the requirements of FAR27.561 and FAR29.561 for High G Emergency Landing Loads while providing unsurpassed level of service and reliability.

The EPIC PLS cot uses Hard-Anodized aircraft-grade aluminum tubular framing to provide unsurpassed strength and rigidity in a lightweight damage tolerant design. The Hard-Anodize coating eliminates abrasion and oxidation and ensures quick and easy decontamination.

The roll-in loading system with actuated folding-legs and mating ramp assembly ensures proper ergonomics during the loading and unloading from the aircraft. Additional standard features include lift-assist pneumatic backrest and one-hand release fold-down side-rails that can also be used for mounting medical equipment including monitors and infusion pumps.

The EPIC PLS 600lb rating easily accommodates larger patients while optimizing the space between patient and operator. The oversized wheels (6x2) with sealed caster and roller bearings provide stability and ease of mobility on all types of terrain.

The flexible design of the EPIC series allows the PLS cot to be interchangeably loaded on the RH side or the LH side of the H145 cabin to accommodate the mission requirements. Additional design features include TSO approved four-point shoulder harness and two lap-belt restraint system, reflective labeling and monogrammed sealed mattress design.



This document contains information confidential and proprietary to Rotorcraft Services Group, Inc. and to its subsidiaries. The document and information contained herein is intended strictly for the use of the Customer and shall not be duplicated, used, or disclosed, in whole or in part, for any purpose other than to evaluate this proposal.

2.3 Secondary Patient Folding Stretcher (PFS)

The secondary patient folding stretcher is designed to meet the requirements of FAR27.561 and FAR29.561 for High G Emergency Landing Loads while providing unsurpassed level of service and reliability.

The EPIC PFS uses Hard-Anodized aircraft-grade aluminum tubular framing to provide unsurpassed strength and rigidity in a lightweight damage tolerant design. The Hard-Anodize coating eliminates abrasion and oxidation and ensures quick and easy decontamination.

The roll-in SLS system uses oversized wheels (4x2) with sealed caster and roller bearing for ease of loading in the aircraft. Quick-folding release handles ensure that the stretcher can be deployed or folded for compact stowage in few minutes.

The flexible design of the EPIC series allows the PFS cot to be interchangeably loaded on the RH side or the LH side of the H145 cabin to accommodate the mission requirements. Additional design features include TSO approved four-point shoulder harness and two lap-belt restraint system, reflective labeling and monogrammed sealed mattress design.



2.4 Integral Medical Floor Assembly

Sealed light weight and high strength honeycomb composite medical floor assembly, with integral fluid barrier and stainless steel thresholds, protects the aircraft floor from incidental damage and from the corrosive effects of fluids spillage. The medical floor installation also includes optional side wall scuff plates to protect cabin interior panels.

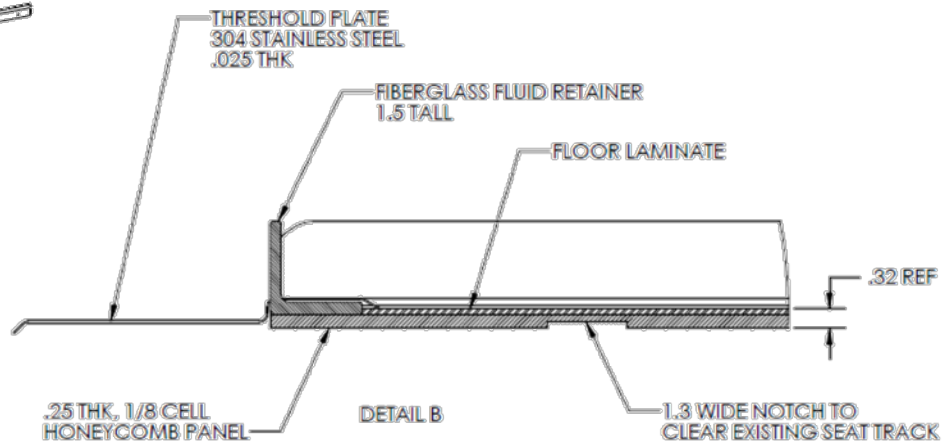
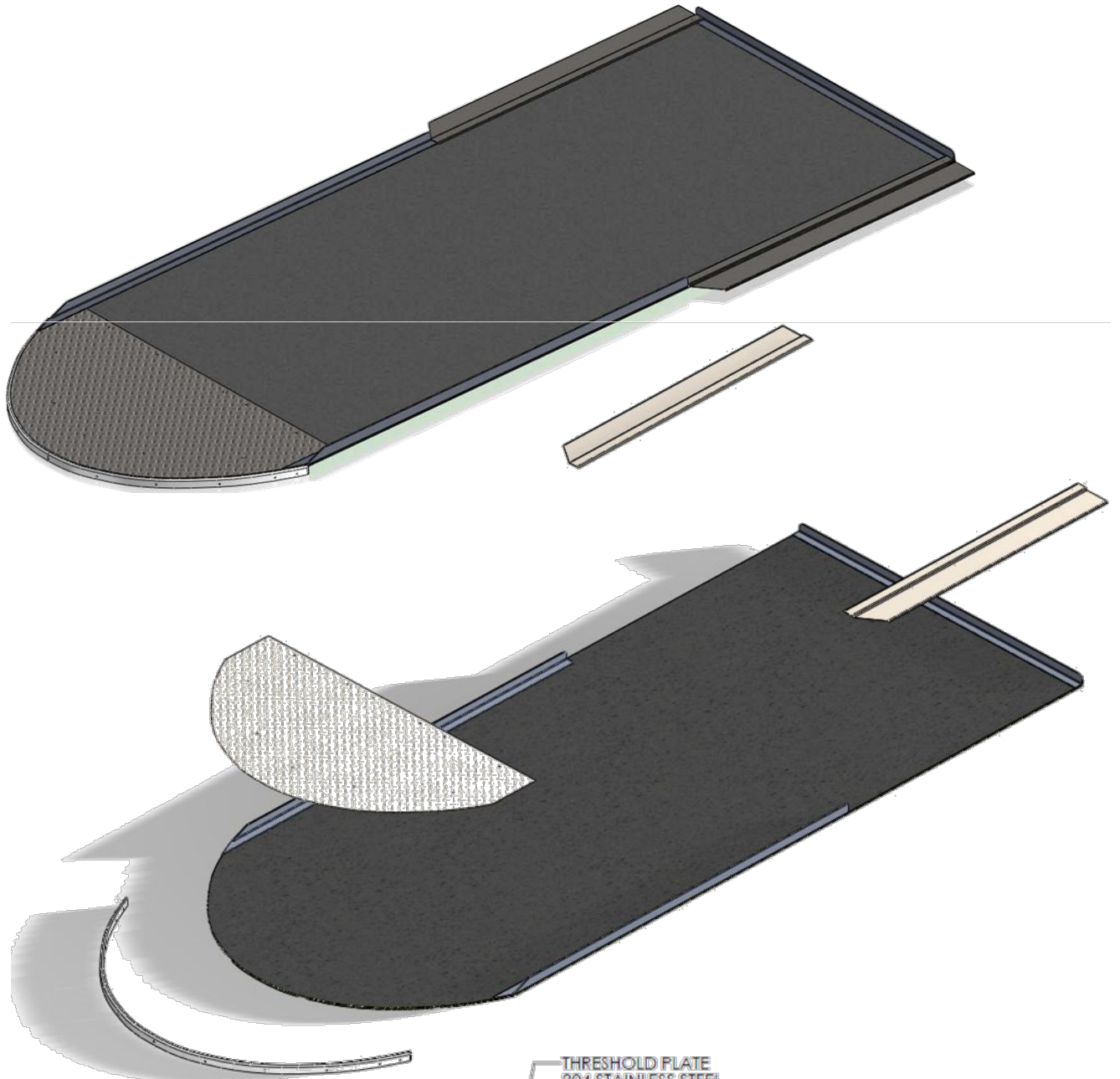

This document contains information confidential and proprietary to Rotorcraft Services Group, Inc. and to its subsidiaries. The document and information contained herein is intended strictly for the use of the Customer and shall not be duplicated, used, or disclosed, in whole or in part, for any purpose other than to evaluate this proposal.

2.5 RHS Tracking Swiveling Medical Attendant Seat

The right hand fore and aft tracking/swiveling medical attendant seat is installed using high strength precision machined medical seat tracks with integral kick-plate design. Hard-Anodize coating eliminates abrasion and oxidation and ensures quick and easy decontamination of track assemblies. The seat design is approved for forward and aft facing with four-point inertial restraint system, two-position recline and adjustable backrest. This medical attendant seat is certified to the requirements of FAR27.561, FAR29.561, FAR27.562 and FAR29.562.



2.6 LHS AFT Facing Medical Attendant Seat

LHS AFT facing medical attendant seat is installed using high strength precision machined medical seat tracks with integral kick-plate design. Hard-Anodize coating eliminates abrasion and oxidation and ensures quick and easy decontamination of track assemblies. The seat design is approved for forward and aft facing with four-point inertial restraint system, two-position recline and adjustable backrest. This medical attendant seat is certified to the requirements of FAR27.561, FAR29.561, FAR27.562 and FAR29.562.

2.7 Center AFT Facing Medical Attendant Seat

Center AFT facing medical attendant seat is installed using high strength precision machined medical seat tracks with integral kick-plate design. Hard-Anodize coating eliminates abrasion and oxidation and ensures quick and easy decontamination of track assemblies. The seat design is approved for forward and aft facing with four-point inertial restraint system, two-position recline and adjustable backrest. This medical attendant seat is certified to the requirements of FAR27.561, FAR29.561, FAR27.562 and FAR29.562.



2.8 Medical Respiratory Gas System

The externally mounted primary respiratory oxygen system provides high capacity of compressed gaseous oxygen with a built-in transfill port for uninterrupted patient service and ease of ground maintenance. An emergency shutoff valve is a standard safety feature of the H145 oxygen system design.

The medical air system uses medical-grade Rocking Piston Air Compressor technology to provide quiet, oil less and reliable operation at 32 Liters of Open Air Flow (12.8 Liter @ 50 PSI Air Pressure) per pump assembly.

The primary suction system uses medical-grade Rocking Piston suction pumps to provide quiet, oil less and reliable operation at 48 Liters of Open Air Flow (17.0 Liter @ 15 PSI Suction Pressure.) patient care.

2.9 Portable Oxygen Provisions

Clamps mounted in the right rear cabin area provide for the installation of a lightweight, versatile and portable supplemental oxygen unit that can offer a wide variety of airway maintenance options both on board and off the aircraft. The clamps can accommodate a "D" size cylinder permitting for the treatment of breathing or non-breathing patient with either liter flow or demand valve capabilities.



2.10 I.V. Hooks

Flush-mounted stowable I.V. hooks are mounted in the cabin overhead. Additional fixed hooks are also provided for flexible patient care.



2.11 Optional Door Post Outlet Panel

Door post mounted Oxygen outlet panels with suction regulator and integral support handles are provided on both the LHS and RHS of the cabin for ease of access.



2.12 Medical Service Panels

Medical grade 110V AC electrical outlets are located within the right and left window along with storage compartments. Oxygen outlets with Regulator, Vacuum Regulator and Indicator are located within the medical panels on left hand and right hand door posts.



2.13 Medical Power Electrical Support Package

The medical electrical support package is designed to provide 110V AC power when the aircraft is not in service. A lightweight, 87% high efficiency static inverter uses the latest state of the art, solid state circuitry to provide 110V, 60 Hz AC electrical power sufficient to operate the most sensitive and demanding airborne medical equipment. The system continuous power rating of 1000 VA and intermittent rating of 1500 VA can be upgraded to 1200VA and 1800 VA respectively.

Medical grade dual and single 110V AC GFI outlets are provided throughout the cabin to meet the specific requirements of the medical program. Shore power receptacle, with cable connected warning, is located on the right hand side of the fuselage near the clamshell door.

2.16 Overhead Medical Console

FM communication radios and audio controls along with EMS Switch Panel, Oxygen Quantity Display are mounted in the upper right hand portion of the cabin area. The controls are within easy reach of the aft facing attendant seats. The Lightweight modular composite console assembly is mounted over the primary stretcher location on the LHS.



2.17 Hi-Bright LED Medical Lighting

Fully dimmable Hi-Bright white LED light assemblies can be operated from 115V AC Shore Power and provide even cabin illumination at a very low power consumption and heat emissions. Green and blue LED lighting is also available as an option for enroute and NVG flight requirements.

2.18 Blackout Curtain

An opaque burn-certified blackout curtain is slide mounted on the overhead between the cockpit and cabin to provide maximum cockpit isolation for NVG operations. The curtain material is washable for easy decontamination.

2.19 Soft Pocket Storage

Soft pocket storage assemblies are mounted below oxygen outlet panels on door post and inboard side of rear doors or to the customer's specifications.

2.20 Clamshell Door Nets

Nets are provided on the interior clamshell doors for additional storage.



H145 Advanced Medical Interior Configuration

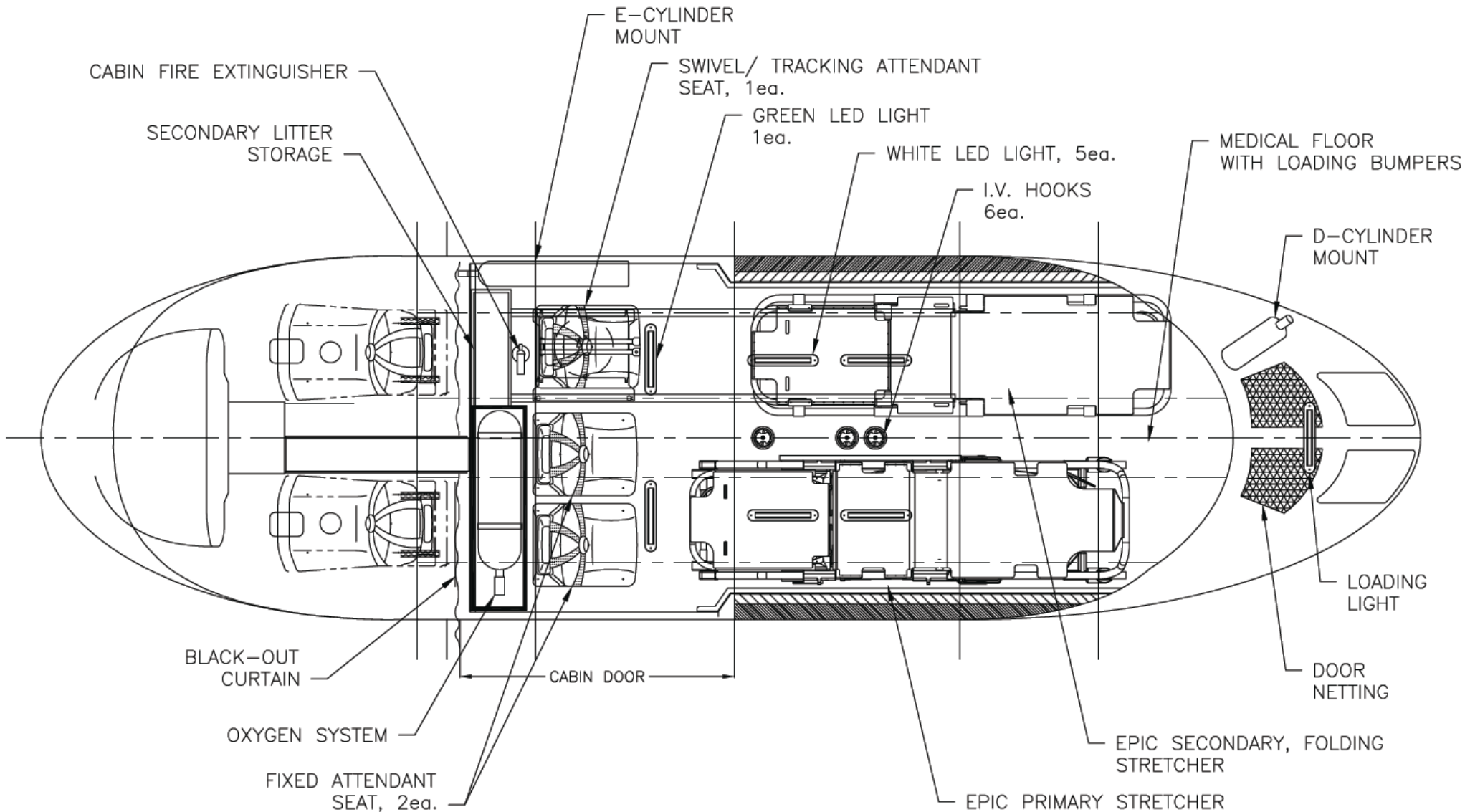

This document contains information confidential and proprietary to Rotorcraft Services Group, Inc. and to its subsidiaries. The document and information contained herein is intended strictly for the use of the Customer (defined as SIKA Interplant Systems Limited) and shall not be duplicated, used, or disclosed, in whole or in part, for any purpose other than to evaluate this proposal.

H145 Medical Floor Layout

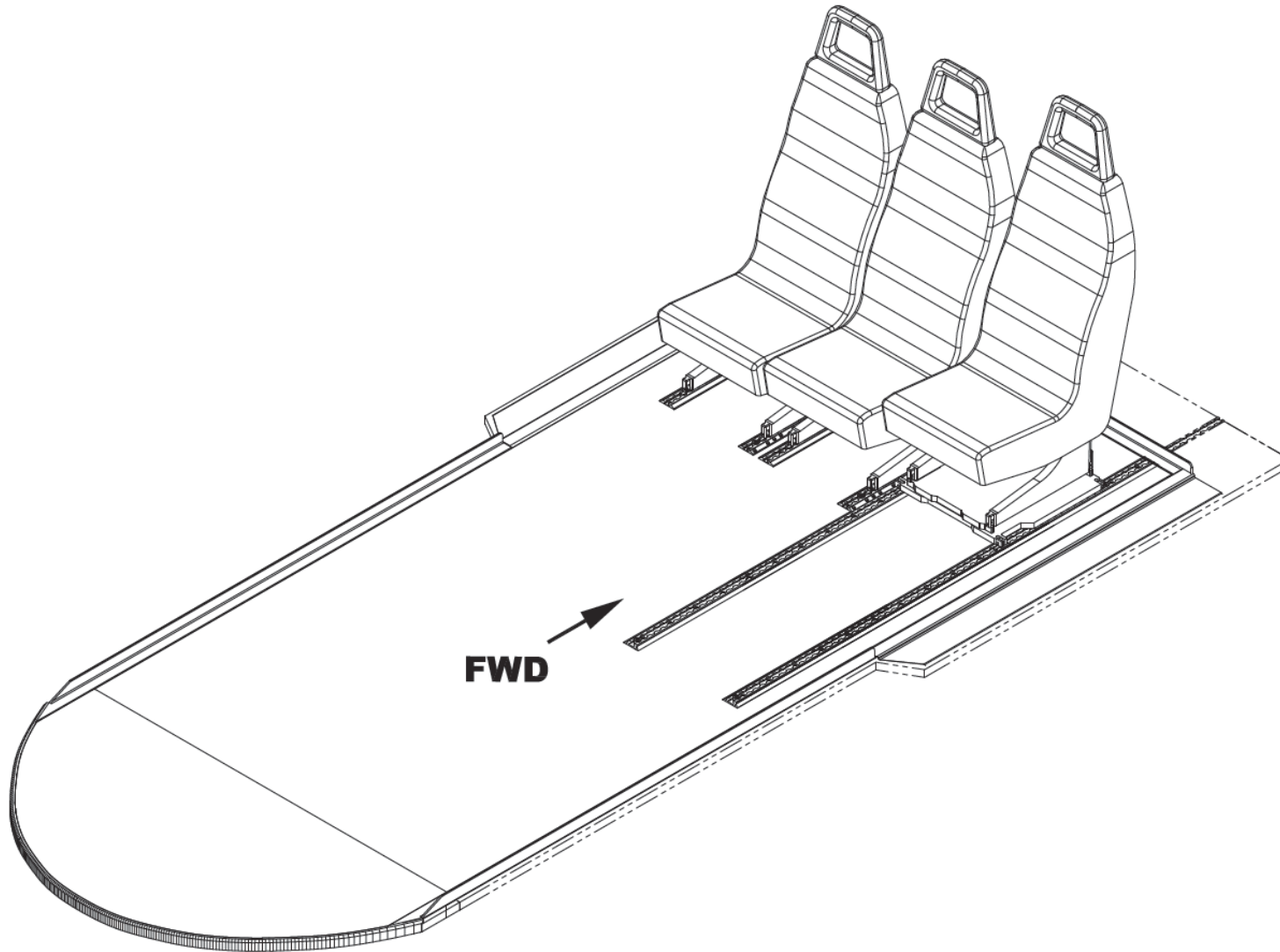

This document contains information confidential and proprietary to Rotorcraft Services Group, Inc. and to its subsidiaries. The document and information contained herein is intended strictly for the use of the Customer (defined as SIKA Interplant Systems Limited) and shall not be duplicated, used, or disclosed, in whole or in part, for any purpose other than to evaluate this proposal.



This document contains information confidential and proprietary to Rotorcraft Services Group, Inc. and to its subsidiaries. The document and information contained herein is intended strictly for the use of the Customer (defined as SIKA Interplant Systems Limited) and shall not be duplicated, used, or disclosed, in whole or in part, for any purpose other than to evaluate this proposal.



This document contains information confidential and proprietary to Rotorcraft Services Group, Inc. and to its subsidiaries. The document and information contained herein is intended strictly for the use of the Customer (defined as SIKA Interplant Systems Limited) and shall not be duplicated, used, or disclosed, in whole or in part, for any purpose other than to evaluate this proposal.



This document contains information confidential and proprietary to Rotorcraft Services Group, Inc. and to its subsidiaries. The document and information contained herein is intended strictly for the use of the Customer (defined as SIKA Interplant Systems Limited) and shall not be duplicated, used, or disclosed, in whole or in part, for any purpose other than to evaluate this proposal.



This document contains information confidential and proprietary to Rotorcraft Services Group, Inc. and to its subsidiaries. The document and information contained herein is intended strictly for the use of the Customer (defined as SIKA Interplant Systems Limited) and shall not be duplicated, used, or disclosed, in whole or in part, for any purpose other than to evaluate this proposal.



This document contains information confidential and proprietary to Rotorcraft Services Group, Inc. and to its subsidiaries. The document and information contained herein is intended strictly for the use of the Customer (defined as SIKA Interplant Systems Limited) and shall not be duplicated, used, or disclosed, in whole or in part, for any purpose other than to evaluate this proposal.



This document contains information confidential and proprietary to Rotorcraft Services Group, Inc. and to its subsidiaries. The document and information contained herein is intended strictly for the use of the Customer (defined as SIKA Interplant Systems Limited) and shall not be duplicated, used, or disclosed, in whole or in part, for any purpose other than to evaluate this proposal.

2.21 Portable Medical Equipment Installation Provisions (LHS & RHS)

The following portable medical equipment and related installation provisions may be provided as a part of the helicopter medical interior. The portable medical equipment will be located for easy access by medical attendants.

The power for portable medical equipment except for the small oxygen tank will be supplied by built-in chargeable batteries to allow the patient care in cabin and during transportation from a helicopter to medical facilities and will be recharged during flight via the medical electrical system.

1. Zoll X-Series Defibrillator/Monitor/Pacemaker



At less than 12 pounds (6 kilograms), the Zoll X-Series is about half the size and half the weight of competitive full-featured monitor/defibrillators. Designed specifically for EMS military and air medical operations, the X-Series offers all options needed in a rugged and portable EMS device.

The Zoll X-Series offers unmatched durability and critical care support. Because of its origins in military and air medical operations, the X Series is the first defibrillator for EMS to earn an IP55 ingress protection rating for dust and water. It's virtually immune to a three-minute, high-pressure onslaught of water and meets the most stringent specifications for shock and vibration. The X Series can also handle three invasive pressures (optional) and two temperatures, often needed in acute critical care.

The X-Series can display up to four waveforms of simultaneously and a 12-lead ECG for onscreen review. The display can also be set to high-contrast black-and-white or night vision mode as required. The built-in CPR Dashboard.™ ensures highest quality CPR performance standards.

For STEMI patients, the X Series is designed to speed door-to-balloon time with quick and accurate 12-lead acquisition, interpretation, and transmission. The printer provides a standard display format for on-scene review, and RescueNet® 12-Lead and RescueNet Medgate programs support 12-lead receipt at participating hospitals.

The noninvasive blood pressure (NIBP) technology* on the X Series is considered the gold standard for NIBP, another feature that sets the X Series apart. Only available on ZOLL monitor/defibrillators, Sure BP® and Smartcuf® make the difference. With Sure BP, pressure readings are obtained in approximately 15 seconds because they're detected during cuff inflation. Smartcuf synchronizes the measurement to the patient's R wave, improving accuracy and reliability.

The X Series also offers unsurpassed data collection and trending capability from a resuscitation device. With integrated WiFi for handling data. Streaming† data can even be sent to hospitals or other remote locations while ensuring optimal patient care. With the Snapshot feature, it's easy to capture an ECG and vital trend data in 12 seconds pre-event and 12 seconds post-event with the press of a button. The X Series has enough memory to store 32 data snapshots, 24 hours of event or trend data in one-minute intervals, and 1,000 time-stamped events.

2. Propaq LT Monitor



The Propaq LT Monitor Features a bright, full-color touchscreen display for continuous vital signs monitoring in hospital environments, during conscious sedation, and pre- and post-operative care. The Propaq LT Monitor has the following features:

- A compact design weighing less than 1 kilo, about the size of the average paperback book
- Shock resistance of up to 75 g, enough to withstand a 1.8 m drop
- Heart rate, 3- or 5-lead ECG, SpO2, NIBP, respiration
- Neonatal, paediatric, and adult patient modes
- Masimo SET® motion-tolerant SpO2 or Nellcor® SpO2
- Highly intuitive, easy-to-use, user interface:
- Custom configurable to user care area
- Operates in spot-check and/or continuous monitoring modes
- Direct-action operation with camcorder-type controls
- Three display modes to accommodate varying user skill-sets
- Colour Transflective LCD, viewable indoors and outdoors
- 24-hour tabular and graphical trending
- Stores up to 20 full-disclosure data snapshots
- Transfers trends and snapshots to PC for printing
- Wireless connectivity option to Acuity® Central Station via FlexNet™
- Smartcuf® NIBP
- U.S. Military flight-certified for fixed- and rotary-wing aircraft

3. B. Braun's Perfusor Space PCA Infusion Pump



B. Braun's Perfusor Space PCA Infusion Pump – with advanced delivery features that offer safety and accuracy – is ideal for adult and pediatric care areas where safe delivery of controlled substances are critical.

As part of the Space Infusion Pump System, the Perfusor PCA provides a shortened training time for staff members with similar user interfaces for PCA, large volume and syringe pump type. The pumps slide and lock onto one another to form a multi-channel device with PCA, large volume and syringe pump capabilities.

The easy-to-learn and easy-to-program system includes built-in error reduction software and a medication library accommodating both hard and soft limits,

large navigational arrows and a screen that remains visible in any light condition.

- Distinctive PCA label differentiates from other pumps
- Alarms are audible and color-coded for easy recognition
- Enhance narcotic security and help prevent tampering using:
 - Locking PCA syringe cap
 - Locking PCA syringe drive arm
 - Keypad lockout code
- Syringes automatically recognized for fast set-up hour lockout time capable
- Flexible mounting options for both horizontal and vertical positioning
- Clearly recognizable bolus button is differentiated from nurse call button

4. B. Braun's Perfusor Space Syringe Pump 3



B. Braun's Perfusor Space Syringe Pump, with advanced delivery features that offer safety and accuracy, is perfect for operating rooms, adult care, pediatric and emergency settings where ease of use and precise medication administration are of critical importance.

Measuring just 9" x 6" and weighing only 3 pounds, the compact and lightweight design of the Perfusor Space Syringe Pump allows easy transport and flexibility in crowded care settings.

The easy-to-learn and easy-to-program system includes built-in error reduction software and a medication library accommodating both hard and soft limits, large navigational arrows and a screen that remains legible in any light condition.

- Easy-to-learn, easy-to-use intuitive user interface
- 1,500-entry drug library available
- Alarms are audible, clearly visible and differentiated using different tones
- Available with or without wireless
- Strong lightweight pole clamp holds up to three pumps mounted horizontally or vertically

5. CareFusion Pulmonetic Systems ReVel ventilator



The ReVel™ ventilator provides portable ventilation on the fly by offering the critical tools and performance you demand for pediatric (≥ 5 kg) to adult patients in emergency transport. The ReVel ventilator empowers you to quickly initiate ventilation from the street, to the stretcher, and across the continuum of care.

- User interface is based on LTV® series platform, providing ease-of-use and reduced training time
- Weighing only 9 ½ pounds, the ReVel ventilator moves easily with the patient in transport
- Small size and ergonomic design allows for ease-of-mounting in ground and air emergency transport vehicles
- From the initial point of emergency ventilation to the ER, no manual ventilation and no disconnection of the patient circuit, ensuring continuously ventilated patient
- Supports invasive, noninvasive and transport ventilation—reducing training time and simplifying ventilator maintenance
- Extreme miniaturization and modular design allows the ReVel ventilator to detach from docking station and move with the patient
- Hot swappable four-hour battery provides uninterrupted power for extended transport capabilities
- Continuous alternate power options from optional DC automobile adapter, dual desktop battery

6. Portable Medical Oxygen Kit



The LifeLine kit is contained in a purpose-made rucksack style carry case for easy transportation to the casualty. It contains a lightweight oxygen cylinder with an integral regulator and a selection of oxygen masks.

Oxygen can be delivered at between 1 and 15 litres per minute. This provides up to half an hours treatment at the highest flow rate, helping to prevent the patient deteriorating prior to the arrival of professional medical assistance.